

Application of Identification Equipment

*Andy Allman, Vice President - Engineering
AMS Controls, Inc.*

Manufacturers are constantly looking for ways to improve the quality of their products and service. These improvements may include adding value to products, increasing production efficiency, and reducing shipping mistakes. In short, these improvements should lead to delivering a better product in a more efficient fashion.

One approach to accomplishing these goals is through the addition of part or package marking to the production process. The intent of this presentation is to describe common reasons for marking, marking technologies, the benefits of integration, and future possibilities for marking.

Along with the mechanics of how the various printing systems work, it is also important to address some of the more practical issues that can arise when adding marking to a production line. While some technologies are a perfect match for a given application, there are often times when the manufacturer must compromise between contradictory requirements. This presentation will help to determine the best possible marking solution.

Reasons for Marking

The metal construction industry has a wide variety of marking needs. Increasingly, manufacturers are required to mark both individual parts as well as packages of parts. Common reasons for marking include:

- Code compliance
- Retail
- Internal production
- Marketing
- Job-site identification
- Packaging
- Dimensional marking

Code Compliance

Almost all building materials are regulated by one or more standards groups. Building inspectors across the country rely on these groups to improve the safety and quality of construction projects. In the last few years many of these groups have begun to mandate the marking of parts. These markings typically include one or more pieces of information, such as the listing or report number, material properties (i.e., gauge, KSI, coating, etc.), coil/heat identification (ID), part type, or dimensional information. In many cases, these marks must be repeated on the parts

within a minimum distance. On structural parts, there is often the

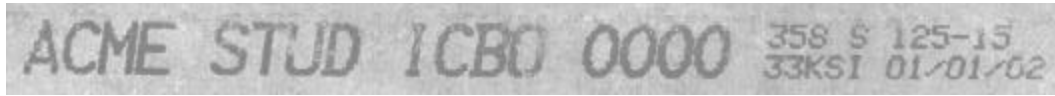

Figure 1 - Sample ICBO marking for a metal stud

additional requirement that the mark be permanent or readable even after painting.

Retail

Companies wishing to sell their products through retail stores must label parts or packages with a Universal Product Code (UPC) bar code. This bar code provides the 11 digit company/product ID number. The first 5 digits of the code are assigned by the Uniform Code Council (UCC) and identify the company. The remaining digits are to identify the specific product and can be assigned by the company. There are standards for the format of the label and the readability of the bar code. The Uniform Code Council web site has plenty of information on the labels, as well as guidelines for establishing a company ID number (www.uc-council.org).

Internal Production

In cases where produced parts are used in assemblies, it can be very useful to have each part marked with its part number and other information. With each part properly labeled, the production staff can be sure that the correct parts are being used for the assembly. This can also be very important for facilities that operate under ISO9000 (or similar) requirements.



Figure 2 - Part label including part, assembly, and order number as well as dimensional information

Part marking can be used to track parts through a production line or to determine what routing or manufacturing steps need to take place for each part. For example, a cut-to-length (CTL) machine could create blanks that are loaded onto turret press/plasma/laser tables. The CTL machine could automatically place a bar code label on each sheet that encodes the file name for the output of the nesting software (i.e., CAD file). The operator of the cutting/punching table would then scan the bar code to automatically load the correct numeric control (NC) program for that sheet.

Marketing

In many cases, simply marking the manufacturer's name or logo can go a long way in increasing name recognition.

Job-Site Identification

At the construction site of a metal building, it is important for all parts to be installed in the proper location (especially for structural members). One method to ensure that parts are correctly used is to mark each one with a unique identifier. This identifier along with the corresponding engineering drawings will reduce the amount of time required by the crew to find a part and the time needed to determine with certainty that it is the correct one.

Packaging

Skids or bundles of produced goods need to be marked for a variety of reasons, including the following:

- To identify the package as it is shipped.
- To identify the contents of the package.
- To provide job-site routing information.

Bar code labels allow companies to scan packages of finished goods as they are loaded onto trucks. This links the packages to the shipment and is often a trigger for invoicing the customer.



Figure 3 - Bundle tag label

A label can also list the actual contents of the package. For example, a skid of metal roofing or siding may contain a number of parts at various lengths. Even though a clerk could look-up the contents of the skid via the package ID, it is much more convenient to have this information listed on the label itself.

The package label can also include information to help the skid get to the proper address

and can even give details on routing it to the correct location once it gets to the job site.

Dimensional Marking

Many printing systems are accurate and repeatable enough to be used to add dimensional marks to parts. These marks can be as simple as the 12" tick marks commonly seen on conduit or sophisticated enough to allow the assembly of roof trusses or wall sections without jigs. For example, the top

and bottom track components of a wall section can be marked with the locations of all the studs and information on what type of stud to use (i.e., short studs for windows). Each end of the wall section can be marked to help properly locate the wall section at the job site. In a similar fashion, roof truss cords can be marked where the web members intersect. In addition to locating the web member, the printer can also show the fastening requirements for that intersection.

When used with the appropriate machine controls, many printing systems are capable of marking to within +/- 1/32" or better accuracy. Such accuracy is possible because the length controller treats the printer as a punch press and the printer responds very quickly and consistently to the trigger signal.

Types of Marking Systems

A wide variety of technologies are available for part or package marking. Finding the best marking system for the job typically involves eliminating possibilities that do not meet the application's requirements followed by careful research and comparison of the remaining choices. All marking technologies have strong and weak points. Factors such as production speed, print quality, print size, consumable costs, and initial cost must be taken into consideration. In this section, the most commonly used marking systems will be explained, along with their strengths and weaknesses.

Ink

Ink-based printing systems can be classified into two groups: fixed message or variable message. Fixed-message printers are economical as long as the manufacturer does not need to change the message very often and can operate with relatively small print areas. These systems are typically based on an inking wheel or pad. The message is changed by replacing the image wheel or pad.

The two most common variable-message ink printing systems used for printing on metal are drop-on-demand (DOD) and continuous-ink-jet (CIJ). These are also referred to as large-character and small-character printers, respectively. In either case, print messages are created as ink drops hit the moving part. For applications where the part is moving at a fixed speed past the print head, a timer can be used to control the firing rate of the ink drops. In cases where the part is moving at varying speeds, it is necessary to coordinate the firing of the drops with the movement of a rotary encoder that is tracking the movement of the part. With this type of system, the machine can be stopped and restarted mid-print without any noticeable change to the resulting print message. With a timer-based setup, the same scenario would result in a blob of ink where the part stopped and distorted text where the machine changed speeds. The

methods for coordinating ink drops and part movement are essentially the same between DOD and CIJ printers. The main difference between the two is the method by which the dots are created.

Drop-on-Demand (DOD) Printers

DOD inkjet printers are typically based on a relatively simple design: the print-head is composed of a number of electrically controlled valves (one per row). Pressurized ink is allowed to escape via a small nozzle when a valve is energized. The drop of ink flies a short distance before hitting the surface that is being marked. The size of the drop is a function of the nozzle size and the amount of time the valve is opened (as well as the ink type and surface condition). These printers typically have seven or more nozzles; the more nozzles, the higher the resolution or number of lines that can be printed simultaneously. In some cases, the print-head has a three-way valve that selects between ink and solvent. The solvent is used to clean out the nozzles or to prepare the printer for an extended shutdown.



Figure 4 - DOD printer

Print height can be varied on most DOD printers either by using more or less nozzles or by changing the angle of the print head. The printer controls must know the correct angle to be able to change the timing of the nozzle firing. Without this feature the text appears italicized. Since the firing of the jets is typically directly synchronized with the encoder signal, the higher the resolution of the encoder, the better the print quality when the print head is angled.

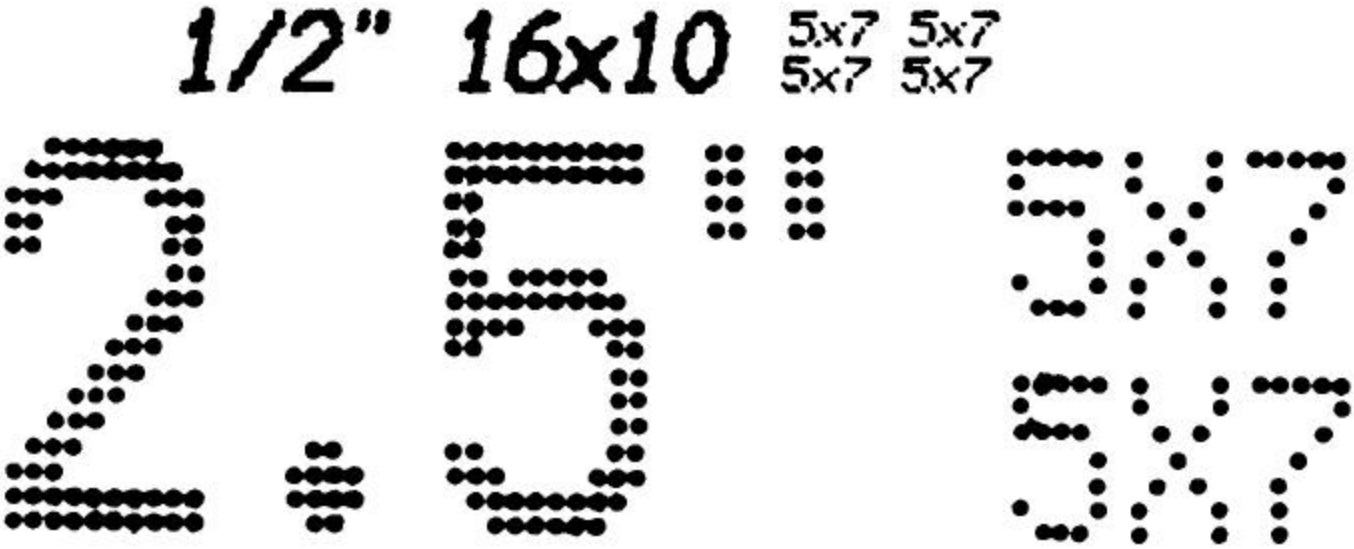

Figure 5 - DOD print samples (16-valve)

One of the most common maintenance issues with DOD printers is clogged nozzles. If the printer is not used for several hours, it is possible for ink in the nozzles to dry up and clog. Brushing the print head with some solvent and a small brush (e.g., a toothbrush) is usually all that is required to fix this problem, although if the clog is bad enough it may be necessary to have the print head sent off for service.

The larger ink drops produced by most DOD printers leads to lower resolutions and higher ink usage. However, these printers are capable of printing much taller messages than CIJ printers. A common range for print heights is ½" to 2".

Continuous-Ink-Jet (CIJ) Printers

CIJ printers are much more sophisticated and operate in a manner similar to that of cathode ray tube (CRT) displays. With a CIJ printer, a single stream of ink is constantly flowing through the system. In the print-head, this stream of ink is broken into a series of droplets as it passes through a crystal that is vibrating at a high frequency (e.g., 60+ KHz). The stream of droplets then goes through a charge tunnel, which applies a specific electric charge to each drop as it breaks off from the stream. These drops then pass through high-voltage deflection plates, which alter the path of the drop based on its electric charge. Whereas in a CRT, the voltage on the deflection plates is varied to guide the stream of fixed-charge electrons, on a CIJ printer the voltage is fixed and the charge of



Figure 6 - CIJ printer

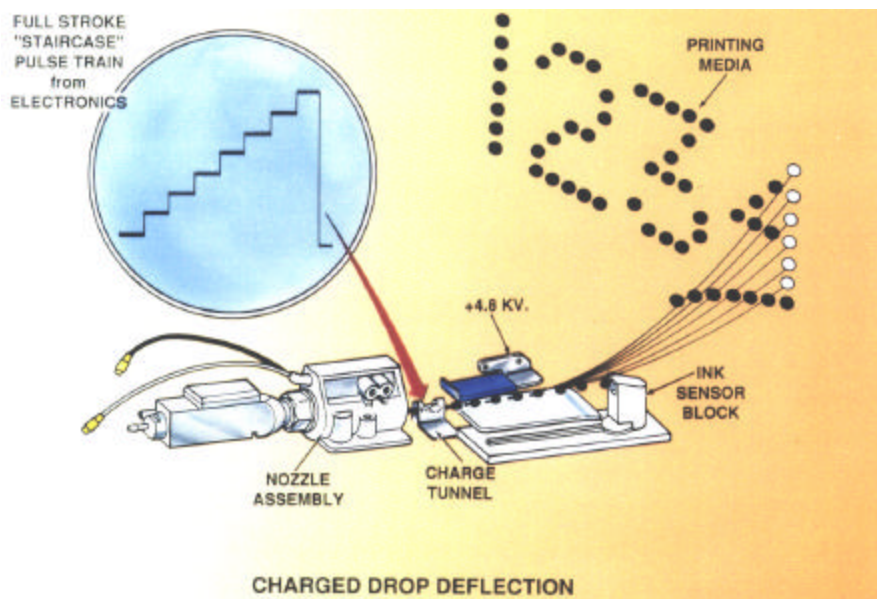

Figure 7 - CIJ ink drop placement

the drops is varied. The higher the charge on the drop, the more it is deflected. A drop with no charge runs right into a vacuum return and is recirculated. In this fashion, a stream of drops can be precisely placed vertically and at a very high rate. Because the stream of ink is constantly exposed to air, the solvent in the ink is evaporating at a fixed rate. The printers measure the viscosity of the ink through a variety of means and add more solvent as needed.

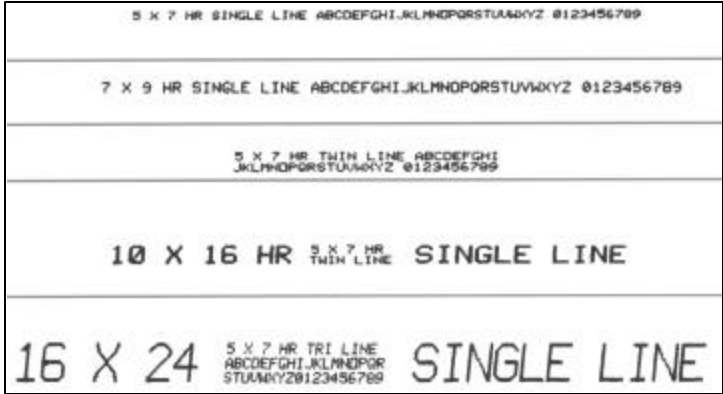

Figure 8 - CIJ print samples

CIJ printers typically offer the best resolution and print quality but have limited print heights (1/8" to 1/2" typically). The print-height limitation is especially true at higher speeds. Because the ink is constantly moving through the system, there is no danger of

an ink clog as long as the proper procedure is followed when the printer is shut down. The very small drop size of a CIJ system allows higher resolution print and greatly reduced ink consumption when compared to DOD printers. The constant loss of solvent regardless of print rates leads to higher consumption of solvent.

Ink Types

There are two major categories of inks that can be used on DOD or CIJ printers: pigmented and dye-based. Pigmented inks contain large particles of pigment that provide the color. Dye-based inks are more like a stain: the resulting color depends on the material being printed on. Dye-based inks are translucent, while pigmented inks are opaque. Because of this difference, the only way to get a white print on a dark background is with a pigmented ink. Since the pigment particles tend to settle over time, it is necessary to agitate these inks to ensure consistent results. If the use of pigmented inks is necessary, it is important to make sure to select a printer that is designed to work with them.

There is a wide variety of solvent bases used with industrial inkjet printers: M.E.K., ethyl acetate, ketone, alcohol, water, etc. Non-water-based inks share the common problem of volatile organic compounds (VOCs). Emissions of VOCs are a function of the volume of ink and solvent used and the composition of the fluids. Material safety data sheets (MSDS) should be consulted when considering the purchase of an ink-based printer. Fume extractors may be required if the VOC levels become too

high around the operator. The various solvents are used to produce different drying times for the ink. On most production machines, fast drying times are desired, so the message does not smear when finished parts are handled or packaged. Faster drying times can also be helpful if the printed message must pass through rollers or other machine elements. Air knives or heaters can be used to shorten the dry time. One problem with inks that dry too fast can occur with metal that has a coating of oil. The ink may dry on the oil before it has a chance to penetrate the oil layer and hit the metal.

In some applications, it is necessary to mark the part before it is painted. Depending on the type of ink and paint used, it may be possible for the ink to bleed through the paint and still be legible.

Bar Codes and Ink Jet Printers



Figure 9 - Bar code produced on CIJ printer

Most ink jet systems are capable of printing bar codes. On higher-resolution equipment such as CIJ printers, the bar codes may even be readable by a bar code scanner as long as they are printed on a relatively non-reflective surface and as long as there is enough contrast between the ink and background. It is difficult (if not almost impossible) to print a reliably-scanned bar code on bare or galvanized metal. For applications where it is necessary to have a bar code on reflective metal finishes, the use of paper labels should be considered.

Paper



Figure 10 - Industrial thermal transfer printer

Thermal transfer printers are most commonly used for package marking, but they can also be used for individual part marking. These industrial grade devices print onto a wide variety of label materials and sizes. This type of printer transfers ink from a ribbon onto a paper or plastic label. Most of the printers currently on the market are based on print engines from Datamax, Zebra, or Sato. These printers are capable of numerous fonts, bar code symbologies, and graphics images. These elements can be placed anywhere on the label in any orientation.

The labels that are used in a thermal transfer printer can be ordered to fit a wide range of requirements such as temperature, moisture, UV stability, or adhesion. Custom labels can be designed with pre-printed multi-color graphics and tear-off sections.

Labels can be hand-applied or automatically applied with a tamp pad. Label printer/applicators use the same thermal transfer print engine but have a rewind roll for the backing material. As the label is printed, it feeds out onto the bottom of the tamp pad. Vacuum pressure keeps the label on the bottom of the pad until it is applied to the part. It is also possible to apply pre-printed labels onto parts. This approach might be useful in cases where the label message does not change very often (i.e., UPC labels on dedicated production machines).

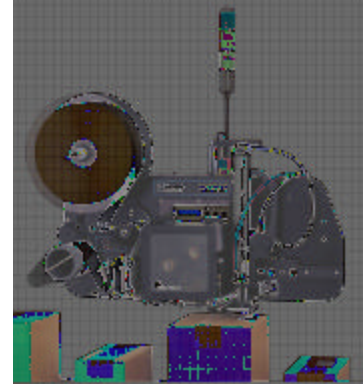

Figure 11 - Label printer/applicator

There are a number of instances where paper labels would not be a good fit. It may be very difficult to get a label to stick to oily or wet metals. Labels can also be scuffed or otherwise damaged when other parts are stacked on top (see figure 2). Paper labels also do not typically handle heat treatments very well. These are cases where a more permanent mark is required.

Embossing

An embossing printer is one in which the print message is created by permanently deforming the surface of the part. This is very useful in cases where paint will be applied after the part is marked or where code compliance requires the use of a permanent mark.



Figure 12 - Embossed print sample

The simplest form of this type of marking system is an embossing wheel that rolls along the part as it is being formed. This results in a short message being repeated every circumference of the marking wheel. The embossing wheels are relatively inexpensive and last a long time. They can work well in cases where the message does not need to be changed very often, is relatively short, and where it can be continuously repeated.



Figure 13 – Indenting stylus printer

If variable messages are needed, there are stylus-based printers that scribe or indent the part. On an indenting printer, the stylus fires at a high speed while the stylus is positioned using a two (or more)-axis positioner. Each stroke of each letter is traced out by the positioner as the stylus fires or is pulled through the material. Scribing printers work in a similar fashion, but the stylus creates continuous lines instead of individual dots. Various fonts and sizes are available, as are graphics and 2D bar codes

(special scanners are required to read these marks). Stylus type printers are slow but require no consumables and can produce permanent messages at a relatively low price.

Burning

Another method for creating a permanent mark is to burn away a small amount of material using a laser beam or a plasma torch.

Laser Beams

Industrial laser printers operate very differently from an office laser printer that prints on paper. Industrial laser printers essentially burn away or discolor the top layer of the material being printed. Low-power lasers are CO₂ based (10-25W), while high-power lasers are often YAG based (neodymium: yttrium aluminum garnet) and provide 50W of power or higher. CO₂ lasers can be used with plastics, paper, or coated (painted) metals. To mark bare metals, the higher power lasers are required.

One type of industrial laser printer operates by steering the generated laser beam via a pair of independent mirrors through a focusing lens at the

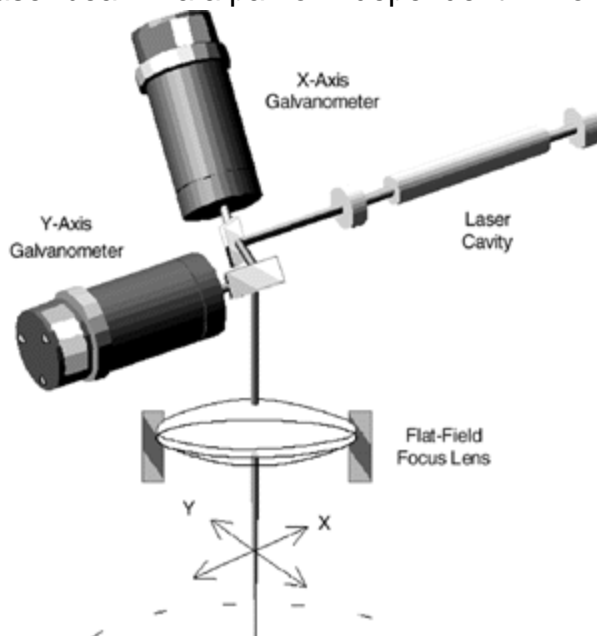

Figure 14 - Steered laser operation

material to be printed. A gating device allows the beam to be turned off while the mirrors are repositioned. As the focused beam hits the material, the sharp rise in temperature burns away the top layer. With a YAG laser, it is possible to anneal or even melt steel. The heating of the surface is a function of both the absorption properties of the material as well as the intensity of the beam. For this reason, it is important to properly match the power of a laser system for each application. In some cases, as the temperature of the

material increases, the absorption rate also goes up leading to much higher temperatures and so on (e.g., runaway heating).

Laser printers can mark a rectangular area (typically within a range of 2" x 2" to 8" x 8") and can be synchronized with a rotary encoder tracking material movement. Print speed is dependent on the "foreground area" of text, as

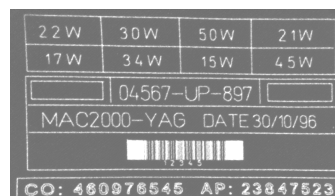

Figure 15 - Laser sample

well as the amount of energy needed to produce a proper mark relative to the power of the beam. Large, fat fonts require more time to produce than a short, thin font.

There are two safety concerns with laser-based printers: the beam itself and the fumes that can be generated by the burning material. Shrouding the beam is often necessary especially with the higher-power systems. Fume extraction equipment may be required as well.

With high-power laser systems, it may be possible to achieve a scannable bar code on bare metal, but much depends on the contrast produced and the abilities of the scanner. For more reliable results, it may be better to pre-coat the printed area with a substance that provides a good contrast when the bar code is burned.

In general, laser-based systems can offer many benefits to offset their relatively high purchase price and the cost of replacement laser tubes (tubes do not last forever and can cost up to 50% of the initial system price). Laser systems do not require any consumables and few printing systems can come close to the print quality of a laser.

Plasma Torch

Another method of burning a permanent mark is with a plasma torch. On many plasma tables, it is possible to specify a secondary torch to be used to mark each part. This is a relatively slow method of printing, but the alternatives are labor intensive and not nearly as fool-proof.

Stand-alone vs. Integrated Printing Systems

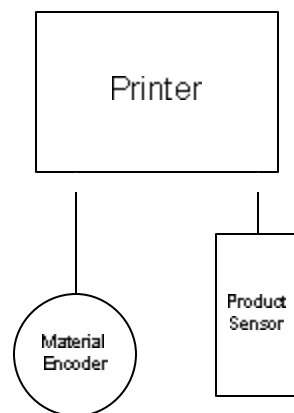

Figure 16 - Stand-alone printer

Most variable-message printing systems include an operator interface for creating and modifying print messages. Messages can include fixed text strings as well as data that is automatically updated by the printer (e.g., date, time, and serial number).

Printing can be triggered based on a product detect input (such as a photo-eye, or proximity switch), on a fixed distance as measured by the encoder, or a combination both. The stand-alone capabilities of most printers can meet the needs of many applications but often require the machine operator to change print message information to stay in sync with the current production setup.

An integrated printing system coordinates the operation of the marking equipment with the machine controls. The machine controller can automatically update the data to be printed and precisely control the location of printed messages on the parts. This integration allows the

machine operator to focus on more important responsibilities, reduces downtime, and can eliminate costly mistakes. It also enables otherwise impossible applications, such as the marking of stud intersections on wall track parts along with code compliance and section ID text.

The coordination between machine controls and a printing system is mainly accomplished through a serial or parallel communications connection. This allows the machine controller to download new print message information to the printer, inquire about the current status of the printer, run diagnostics or maintenance functions, and report back any errors. The initiation of printing can be triggered

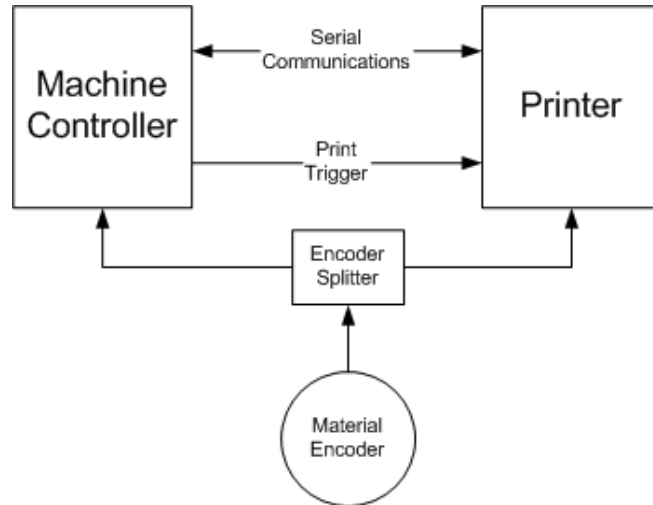

Figure 17 - Integrated printing system

through the communications link or through a hardware I/O line. The hardware approach should provide much more accurate placement of a print message, since most printers react to this trigger with an extremely short and repeatable delay. Both the machine control and printer can share a single material encoder through the use of a signal splitter.

There are almost as many communications protocols for industrial printers as there are printer models. Many printer manufacturers use a common interface for many of their own models, but even this is not always true. In many cases, there is a wide variation of capabilities between different models. Thermal transfer printers provide a very rich set of fonts, barcodes, graphic elements, sizing, placement, and rotation options for print messages. Seven-nozzle DOD inkjet printers can only offer a tiny fraction of these options.

Integrated printing systems certainly require more development time on the part of machine control vendors and somewhat higher costs for end-users, but the resulting increases in efficiency and reliability provide an almost immediate payback of the additional cost.

RFID: Marking Option of the Near Future?

In the last few years, the use of Radio Frequency Identification (RFID) tags has become an increasingly practical option for the marking of parts and packages. This technology has been popularized by Mobil's SpeedPass and automatic toll booth passes.

RFID tags consist of an antenna and an integrated circuit. The data stored on the IC can be transmitted in response to a request from a reader device. Passive RFID tags have no internal power source; they get the necessary power from the RF field. Active tags include a battery and are capable of a much longer range. The data on these tags can be read-only (for serial numbers), writable, or a combination of the two. The information on writable tags can be updated again and again. Another feature of RFID tags is the ability to read multiple tags simultaneously. For example, the contents of a box of clothes with RFID devices sewn into the tags could be instantly inventoried without opening the box.

Wal-Mart recently attempted to move RFID tags to their store shelves. The company had mandated a move towards “smart shelves” that could automatically inventory themselves. A planned trial with Gillette products was cancelled this summer due to concerns from privacy advocates over the possibility of tracking customers through tags embedded in their purchases. This concern is being addressed through the use of a “kill” command that would be issued after the item has been scanned by the cashier. In halting the trial, Wal-Mart announced they would be focusing on the use of RFID tags in the distribution side of their business and were encouraging their top 100 suppliers to incorporate RFID tags in their shipping containers. Since Wal-Mart was largely responsible for the overwhelming adoption of bar codes for retail in the 1980’s, there is a good chance that their support will help RFID technology take off (at least in the area of supply chain management).

RFID tags come in variety of frequency and ranges:

Classification	Frequency	Range
Low-frequency (LF)	125KHz	10 inches
High-frequency (HF)	13.6MHz	3 feet
Ultra-high-frequency (UHF)	433MHz – 2.45 GHz	3-10 feet

Texas Instruments, Symbol Technologies, and Zebra have recently formed an alliance for the development and promotion of UHF RFID technology and products. Zebra has developed a variation of a thermal transfer bar code printer that includes an RF encoder and reader. The label stock used with this printer includes a thin, flexible RFID tag. This tag is encoded and verified before the thermal transfer printing takes place. Symbol is developing RFID readers that operate in a similar fashion as their bar code scanners. Texas Instruments is responsible for the development of the RFID tags themselves, as well as components used in the encoders and readers. The current cost of passive RFID tags is as low as \$0.10-\$0.50 per tag. As these tags are used in higher volumes, this price is sure to drop.

An obvious application of RFID technology in the metal building industry would be to supplement the use of bar codes on bundle tag labels. These tags are very often scanned as the truck is being loaded. With RFID tags,

this step could be replaced by the use of a reader that could record all the information off the various bundles simultaneously as the truck pulls away from the bay. Because RF signals do not easily pass through metal, applying a tag to each sheet is currently impractical. The RFID tag would need to be located on the outside of the bundle in order for it to be readable.

Going Forward

When starting a new part or package marking project, it is important for the implementation team to first ask a few key questions:

- What information needs to be marked?
- How often does the information change?
- What is the desired size of the marking?
- What is the quality level required?
- How durable/stable does the mark need to be?
- What type of surface is being marked?
- Will there be coolant or oils on the surface of the part before or after it is printed?
- Are there secondary processes that may affect the mark (ovens, painting, forming, etc.)?
- How fast is the machine running?

The answers to these questions will come from a variety of sources. Flexibility should be a key requirement of any marking system. It is possible that a colleague in marketing will provide one set of requirements when the project begins and a different set later. Regulatory bodies update their standards from time to time. Machine specifications change as well.

The answers to these questions will also shorten the list of possible printing technologies and models. With the remaining options the following issues need to be considered:

- What is the cost and usage rate of the consumables (if any)?
- How large is the initial capital investment?
- What are the maintenance requirements?
- What are the most common repairs needed, how often do they occur and how expensive are they?
- Are there VOCs generated or other potential operator hazards?
- Can the system be integrated with the machine controls?

If flexibility is a requirement, it is almost always possible to justify the integration of the printer with the machine controls. Relieving the operator from having to keypunch new information every time the product changes should increase the throughput of the machine and increase its reliability.

Good attention to these items early on in a project will lead to the best results and fewer unpleasant surprises. It may not be possible to achieve a perfect fit, but at least a good balance between conflicting requirements can be found.

Credits

Figure 4 – Matthews International

Figure 6 – Videojet Technologies

Figure 7 – Videojet Technologies

Figure 8 – Videojet Technologies

Figure 10 – Zebra Technologies

Figure 11 – Diagraph Corporation

Figure 13 – Telesis Technologies

Figure 14 – Baublys Control Laser Corporation

Figure 15 – Matthews International