



MP465 Panel Mount Controller
for Cut-to-Length Machines

***Technical Reference &
Installation Guide***

Copyright © 2008 – AMS Controls, Inc. All rights reserved.

The information contained in this document is proprietary to AMS Controls, Inc., and is not to be reproduced in any form without the specific written authorization of AMS Controls, Inc.

AMS Controls, Inc. reserves the right to change the contents of this manual without customer notice or permission. The procedures described in this handbook must be performed only by trained, certified industrial electricians in accordance with local, state, federal, and NEC codes and regulations. While AMS Controls has taken all reasonable care to develop safe procedures, it accepts no responsibility for misprints, or for injuries, damages, death, or destruction to persons or equipment caused as a result of not closely following these instructions. For specific controller questions, contact AMS Controls Inc.

The most current version of this manual is always available at:
www.amscontrols.com/files/manuals/default.asp

AMS Controls, Inc.
12180 Prichard Farm Road
Maryland Heights, MO 63043

314.344.3144 – 1-800-334-5213 (US & Canada) – fax: 314.344.9996 – info@amscontrols.com

www.amscontrols.com

Table of Contents

TABLE OF CONTENTS	I
CHAPTER 1: INTRODUCTION.....	3
OVERVIEW.....	3
<i>Features</i>	<i>3</i>
CHAPTER 2: INSTALLATION SPECIFICS.....	4
MECHANICAL DETAILS.....	4
<i>Dimensional Drawing.....</i>	<i>4</i>
<i>Cutout Drawing</i>	<i>5</i>
ELECTRICAL DETAILS.....	5
<i>Specifications</i>	<i>5</i>
Power	5
Inputs.....	6
Outputs.....	6
Encoder	6
Environmental.....	6
<i>Pin Assignments and Descriptions.....</i>	<i>7</i>
J301	7
J401	8
SAMPLE INTERFACE DRAWING.....	9
SOFTWARE CONFIGURATION.....	10
<i>Setup Screen.....</i>	<i>10</i>
Navigate the Setup Screen	10
Setup Parameters.....	11
CHAPTER 3: OPERATIONAL REFERENCE	13
POSITIONING CONTROL	13
<i>Speed Logic Table.....</i>	<i>13</i>
<i>Speed Diagram for Two-Speed Positioning.....</i>	<i>14</i>
<i>Adaptive Stopping Compensation</i>	<i>14</i>

Chapter 1: Introduction

Overview

The AMS Controls MP465 is an industrial controller used to control cut-to-length machinery. Figure 1 shows the front panel of the MP465.

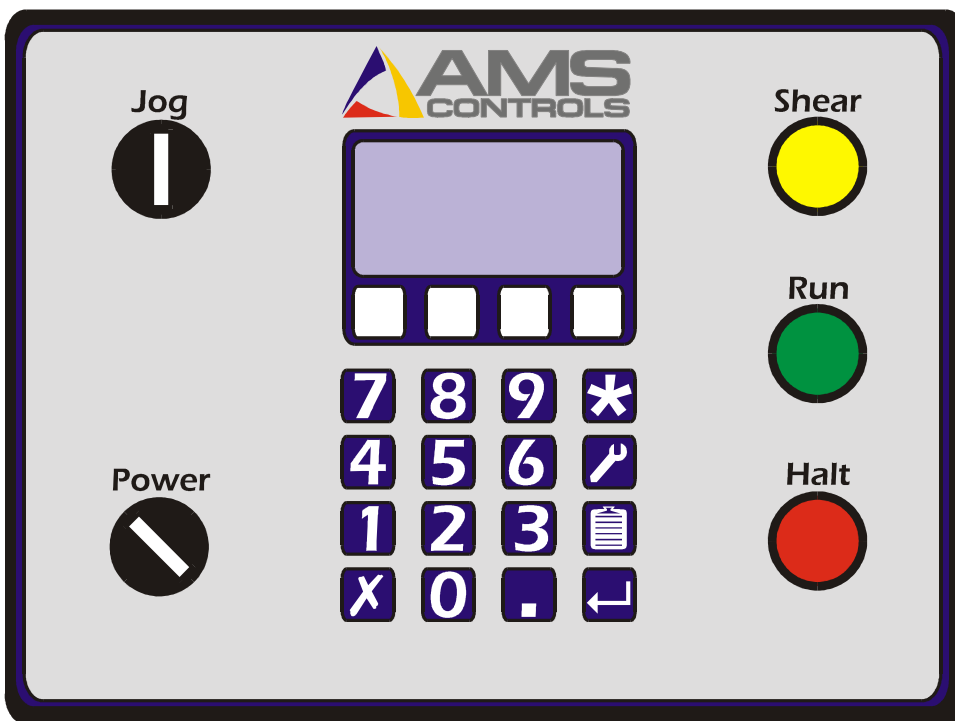

Figure 1: AMS Controls MP465 Controller

Features

The MP465 controller's features include:

- Accurate length control
- Simple programming
- Easy calibration

Chapter 2: Installation Specifics

Mechanical Details

Dimensional Drawing

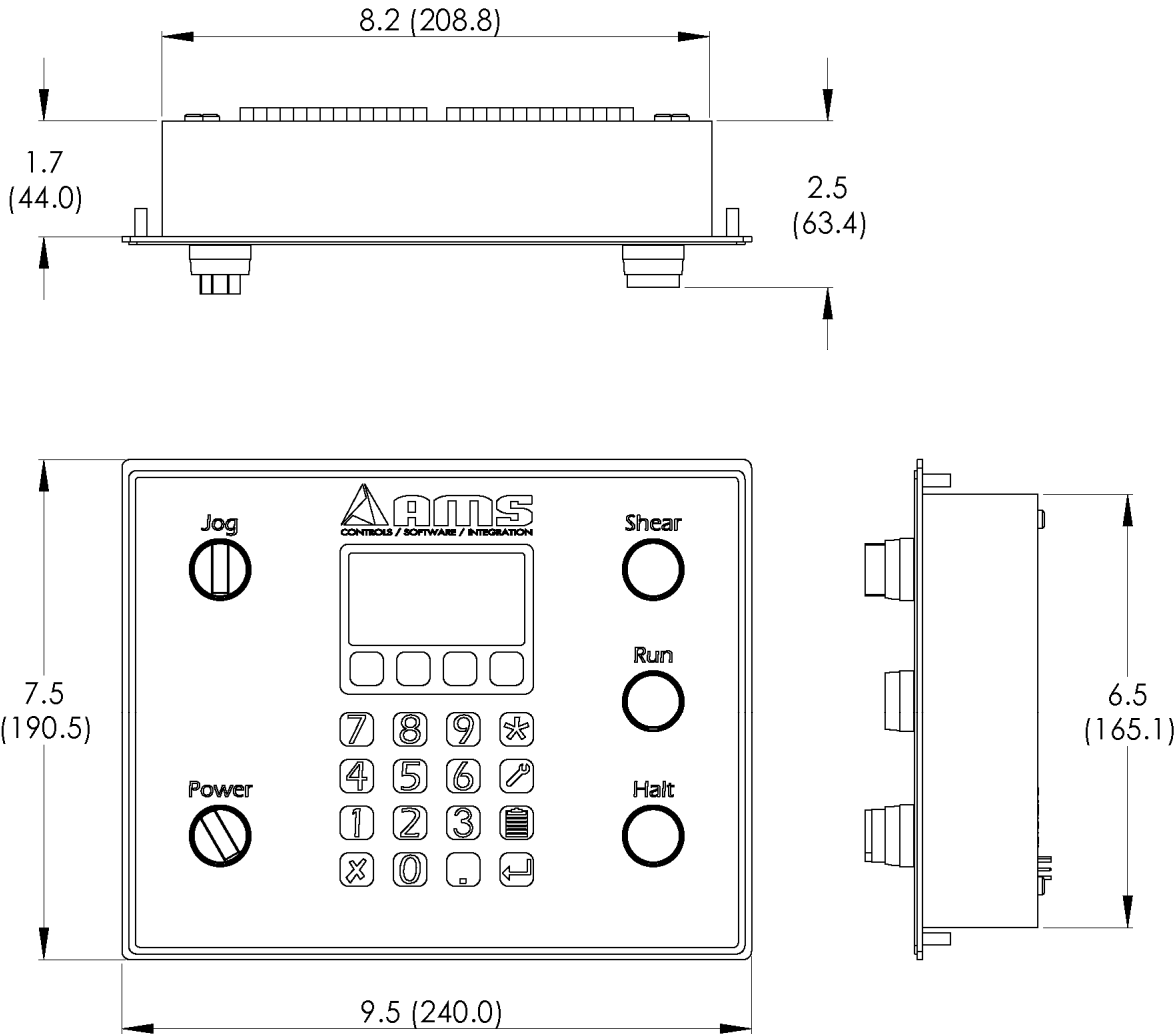

Figure 2: MP465 Dimensional Drawing

Cutout Drawing

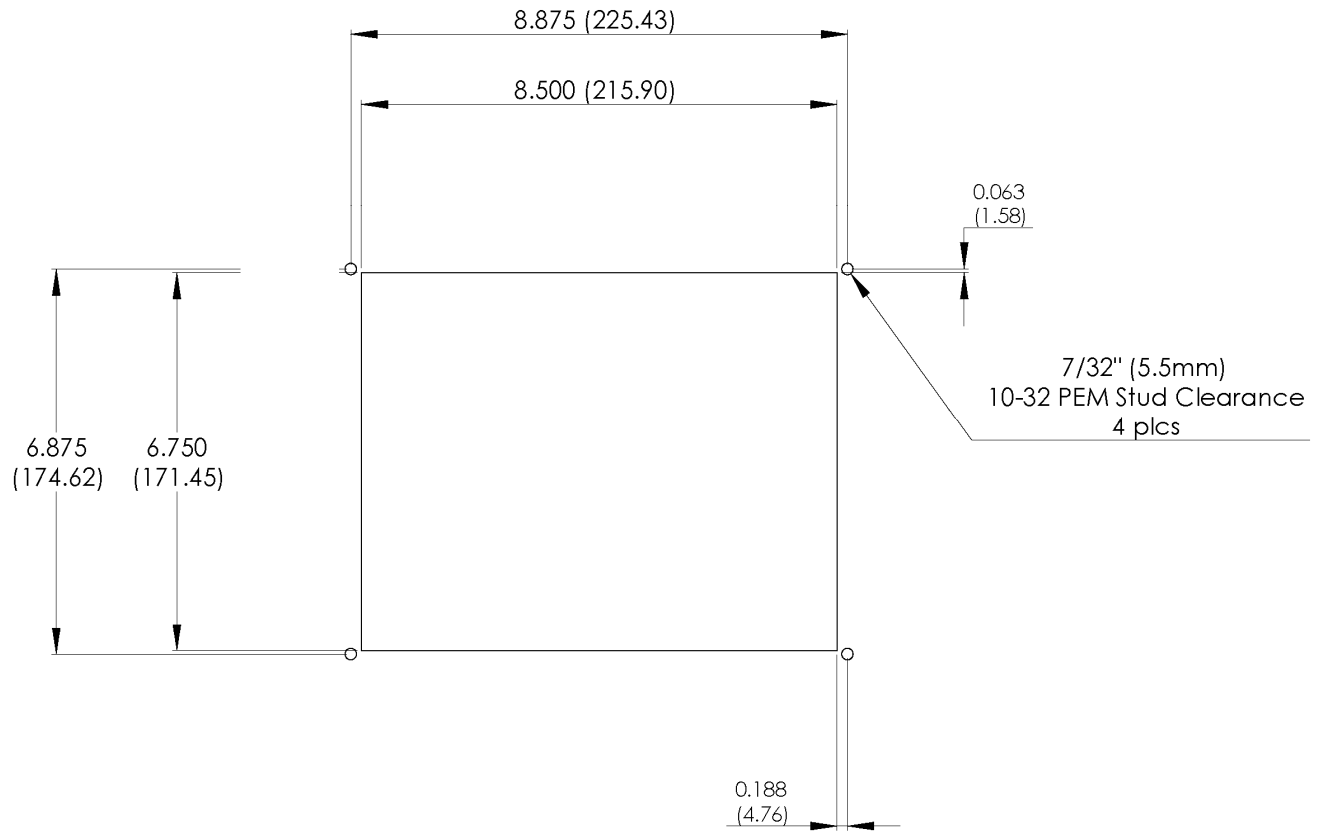

Figure 3: MP465 Cutout Drawing

Electrical Details

Specifications

Power

Supply voltage	24VDC (+/- 20%)
Supply current	400mA + Outputs
Max. inrush current	2A

Inputs

Type	Sourcing
Voltage	24VDC
Input resistance	1.8 K Ω
“ON” voltage	13.4 VDC
Optical Isolation	2500V

Outputs

Type	Sourcing
Voltage	24 VDC
Continuous Current	3A
Optical Isolation	2500V

Encoder

Supply voltage	5 VDC
Supply current	100mA
Type	Quadrature, differential (RS485)
Max. frequency	50 KHz
Optical Isolation	2500V

Environmental

Min. operating temp. (ambient)	-20C (-4F)
Max. operating temp. (ambient)	65C (150F)
Min. storage temp.	-30C (-22F)
Max storage temp.	85C (185F)

Pin Assignments and Descriptions

J301

Pin	Function	Assignment/Notes
1	I/O Ground	6A maximum
2	Output 1	Fast
3	Output 2	Shear Down
4	Output 3	Reverse
5	Output 4	Shear Up
6	Output 5	Slow
7	I/O Ground	6A maximum
8	I/O V (+24V)	
9	Input 1	Shear Up
10	Input 2	Not Used
11	Input 3	Shear Down
12	Input 4	Remote Run
13	Input 5	Not Used
14	I/O V (+24V)	

J401

Pin	Function	Notes
1	RS485 2B+	Unused
2	RS485 2A-	
3	RS485 1A+	For firmware updates
4	RS485 1B-	
5	Encoder A+	
6	Encoder A-	
7	Encoder B+	
8	Encoder B-	
9	Encoder +5V	
10	Encoder Ground	
11	Power +VDC	
12	Power Ground	
13	Power switch contact A Panel Switch	20A maximum
14	Power switch contact B Panel Switch	20A maximum

Sample Interface Drawing

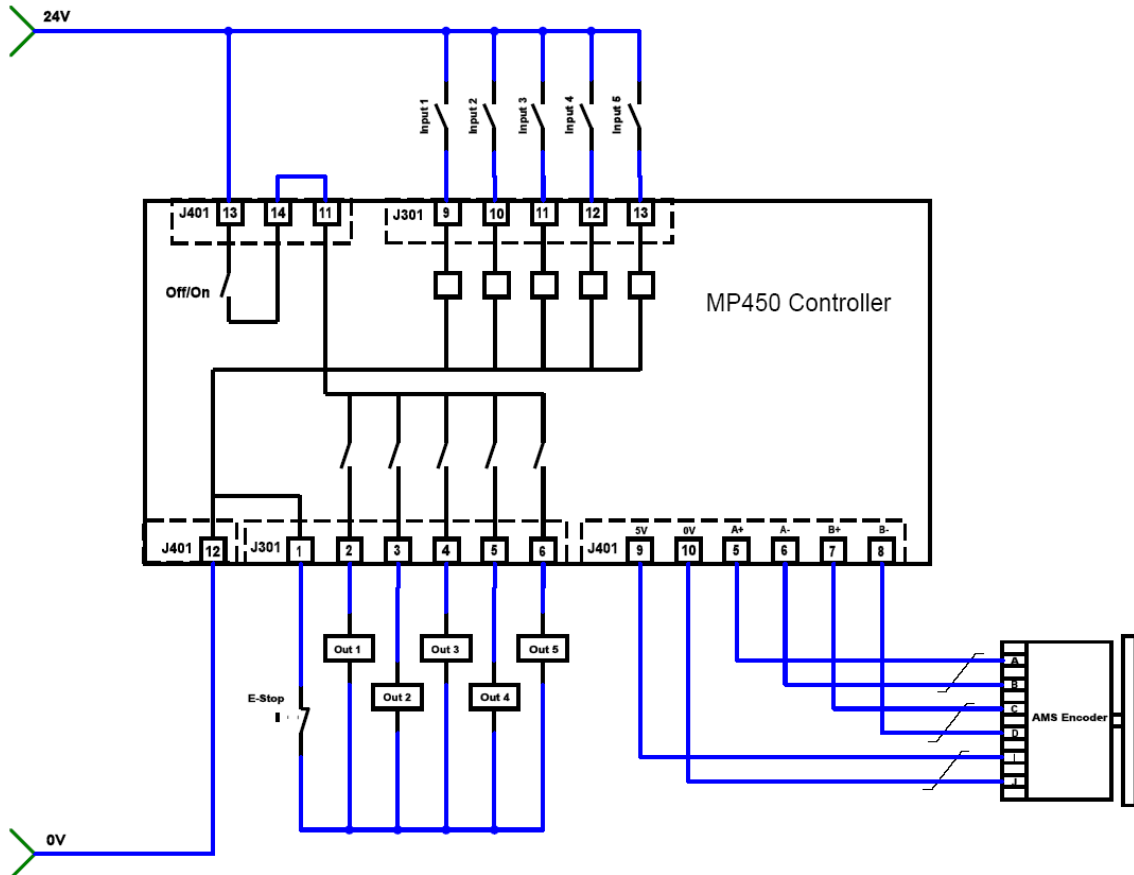

Figure 4: MP465 Sample Interface Drawing

Software Configuration

Setup Screen

Use the Setup screen to change the display units, encoder direction and slow distance.

To enter the setup screen,



1. Power up the system.
2. While the startup screen displays, press [9]. The Setup screen displays.

Navigate the Setup Screen

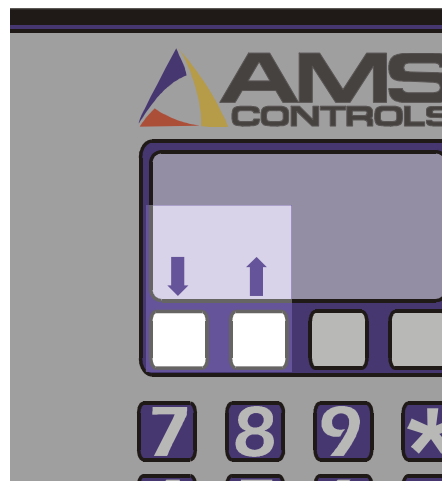
- Use the Up and Down soft keys (white keys just below the display, see Figure 5) to navigate from item to item.



**Figure 5: AMS Controls MP465 Controller front panel
(Up and Down Soft Keys highlighted)**

- Press a number key to change a selected setting temporarily, causing the field to blink.
- Press [Enter]  to save the new setting and move to the next setup item, or [Clear]  to restore the value to its original value.
- Press the Up (↑) or Down (↓) arrow keys while a field is blinking to restore its original value and move to the next item.

Setup Parameters

 **Note:** These parameters retain their value while the machine is powered off.

Display Units

The display unit setting enables the operator to choose between viewing the part length in either feet and inches or metric millimeters.

Encoder Direction

The encoder direction allows the operator to change the direction of the encoder without modifying the machine wiring.

Changing this setting is necessary, for example, if the material position is shown to be moving backwards on the controller while the material is actually moving forwards. You would use this parameter, then, to reverse the encoder direction for the controller so it can register forward and backward movement correctly.

Slow Distance

The distance that the controller feeds in slow speed before stopping for the cut operation.

The accuracy of a two-speed stopping control system depends on a stable slow speed. Through experimentation, it is possible to find a value that provides a good balance between accuracy and productivity.

If this parameter is set to zero, the controller operates in single speed mode, where it decelerates from fast speed to zero velocity. While this may increase the production of the machine, typically it is difficult to achieve good part length accuracy in this mode.

Other Parameters

There are other parameters that are not cleared at the controller on a memory clear.

Footage Totalizer

The total amount of footage through the machine since the totalizer was last cleared. This value is accessed by pressing the Calibration button  two times. The Totalizer can be reset by pressing [Clear] when the total is displayed.

Then, at the prompt “Enter Code to Clear Total,” enter 1984 and press [Enter].
The total will reset to zero.

Chapter 3: Operational Reference

 **Note:** For details on operating a machine with the MP465 Controller, see the MP465 Operator Manual.

Positioning Control

Speed Logic Table

Function		Output			
		<i>Slow</i>	<i>Fast</i>	<i>Reverse</i>	
<i>Jog Forward</i>		Off	On	Off	Manual
<i>Jog Reverse</i>		On	Off	On	
2-Speed Mode	<i>Run Fast</i>	Off	On	Off	Automatic
	<i>Run Slow</i>	On	Off	Off	
Single Speed Mode	<i>Run</i>	Off	On	Off	

Speed Diagram for Two-Speed Positioning

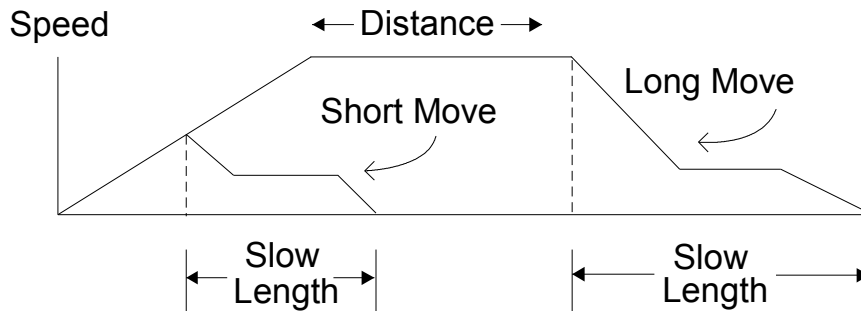

Figure 6: Speed Profile with Adaptive Stopping

Adaptive Stopping Compensation

Adaptive stopping compensation is a feature that enables the controller to account for changes in the amount of time required to bring moving material to a stop.

With a stopping control system, the controller must turn off the motion output before the desired target position is reached. The material then decelerates to a stop and is hopefully within the desired tolerance.

The MP465 constantly monitors the deceleration rate of the machine and makes slight adjustments to the time at which the motion output is turned off. This constant monitoring and adjustment is an important feature for machines that have stopping dynamics that change over time. This is especially an issue with hydraulics-based motion control where the temperature of the oil can affect the stopping behavior of the machine.